



SÉRIES DX SERIES

3000 VA, # DE PIÈCE / PART # : DX 3000QHU

SPÉCIFICATIONS ÉLECTRIQUES / ELECTRICAL SPECIFICATIONS

<p>PHASE: 1</p> <p>FREQ.: 60 Hz.</p> <p>CLASSE ISOL. / INSUL. CLASS: H(180°C)</p> <p>ELEV. TEMP. / TEMP. RISE: < 115°C</p>	<p>TENSION / PRIMARY / PRIMAIRE / VOLTAGE</p> <table border="1" style="width:100%; border-collapse: collapse;"> <tr> <td style="width:15%; text-align: center;">600</td> <td style="width:85%;">2, 2 ½ % ANFC, 2, 2 ½ % BNFC</td> </tr> </table>	600	2, 2 ½ % ANFC, 2, 2 ½ % BNFC	<p>TENSION / SECONDARY / SEC. / VOLTAGE</p> <table border="1" style="width:100%; border-collapse: collapse;"> <tr> <td style="width:15%; text-align: center;">120/240</td> </tr> </table>	120/240																	
600	2, 2 ½ % ANFC, 2, 2 ½ % BNFC																					
120/240																						
		<table border="1" style="width:100%; border-collapse: collapse;"> <thead> <tr> <th>PRIMARY VOLTS</th> <th>CONNECT PRIMARY LINES TO</th> <th>INTER-CONNECT</th> <th>CONNECT SECONDARY LINES TO</th> </tr> </thead> <tbody> <tr> <td style="text-align: center;">600</td> <td style="text-align: center;">H1 - H4</td> <td></td> <td></td> </tr> <tr> <td colspan="4" style="text-align: center;">SECONDARY VOLT</td> </tr> <tr> <td style="text-align: center;">120</td> <td></td> <td style="text-align: center;">X1 to X3 X2 to X4</td> <td style="text-align: center;">X1 - X4</td> </tr> <tr> <td style="text-align: center;">240</td> <td></td> <td style="text-align: center;">X2 to X3</td> <td style="text-align: center;">X1 - X4</td> </tr> </tbody> </table>	PRIMARY VOLTS	CONNECT PRIMARY LINES TO	INTER-CONNECT	CONNECT SECONDARY LINES TO	600	H1 - H4			SECONDARY VOLT				120		X1 to X3 X2 to X4	X1 - X4	240		X2 to X3	X1 - X4
PRIMARY VOLTS	CONNECT PRIMARY LINES TO	INTER-CONNECT	CONNECT SECONDARY LINES TO																			
600	H1 - H4																					
SECONDARY VOLT																						
120		X1 to X3 X2 to X4	X1 - X4																			
240		X2 to X3	X1 - X4																			

SPÉCIFICATIONS MÉCANIQUES / MECHANICAL SPECIFICATIONS: (dimensions = pouces/Inches).

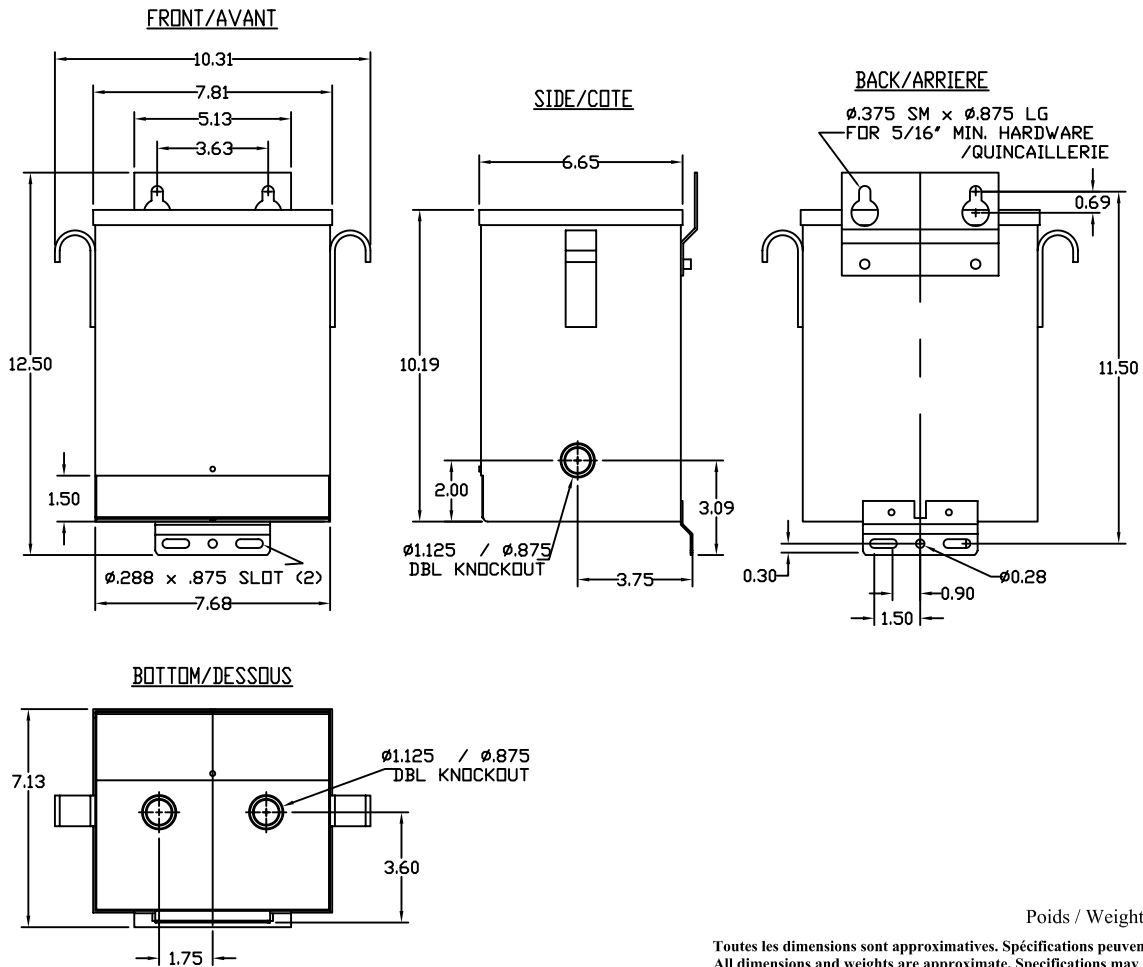

Poids / Weight : 34 Kg (75 lbs)

Toutes les dimensions sont approximatives. Spécifications peuvent changer sans préavis.
All dimensions and weights are approximate. Specifications may change without notice.



NUMÉRO DE MODÈLE:
MODEL NUMBER:
DX 3000QHU

ZONE	REV	REVISION	DESCRIPTION	DATE	APPROVAL APPROB.

Dessiné par: / Drawn by: SS

DWG NO. 71CUDX3000QHU

REV 00

DATE: APRIL 19th 2010

PAGE: 1 de 1